



Name: Floorstand EcoLock

Model Number: #17.1055

Instructions ID: #00.5073~B



Floorstand EcoLock

ASSEMBLY INSTRUCTIONS

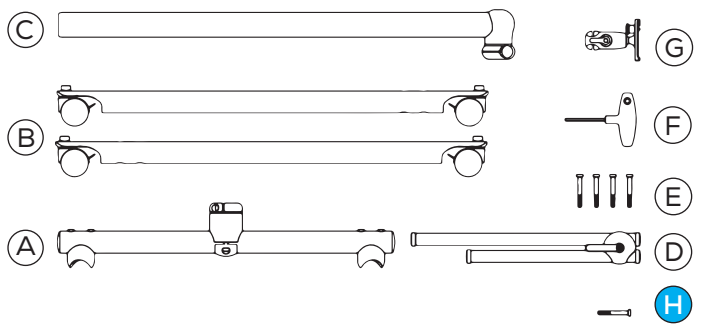

Replacement / Austausch

i Mounting kit / Montageset

- A** = 1x FS traverse
FS Traverse
- B** = 2x FS leg
FS Bein
- C** = 1x FS column
FS Säule
- D** = 1x FS arm
FS Arm
- E** = 4x M8x50 screw
M8x50 Schraube
- F** = 1x T-handle
T-Griff
- G** = 1x UDS
UGA
- H** = 1x M8x50 screw
M8x50 Schraube

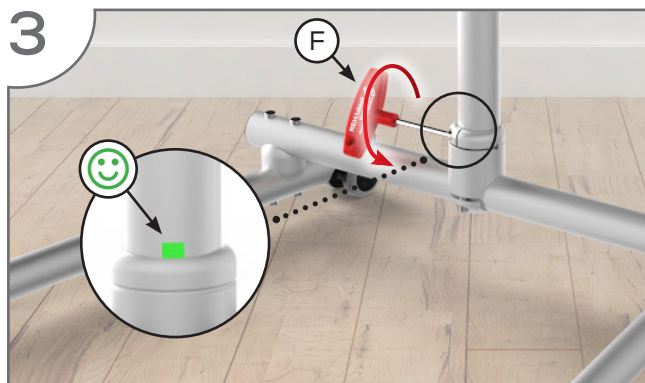
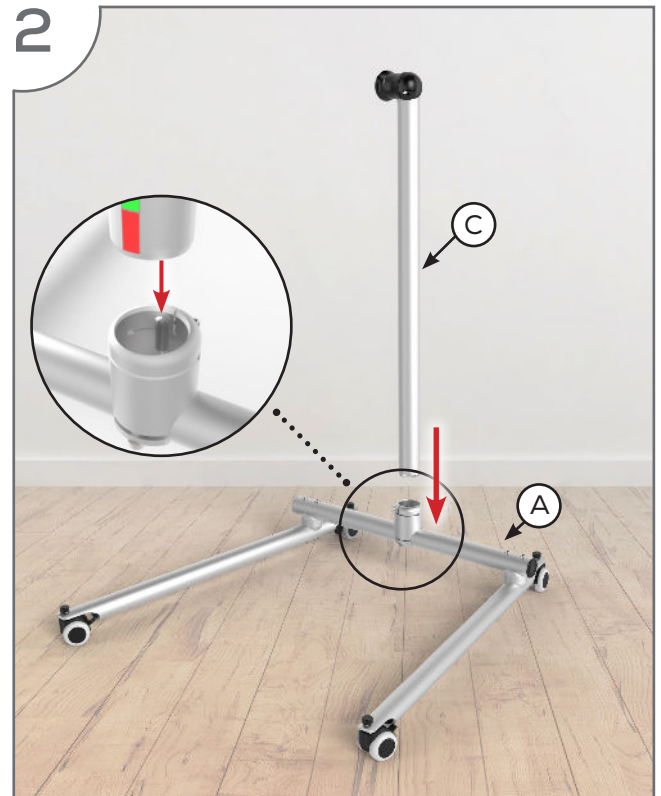
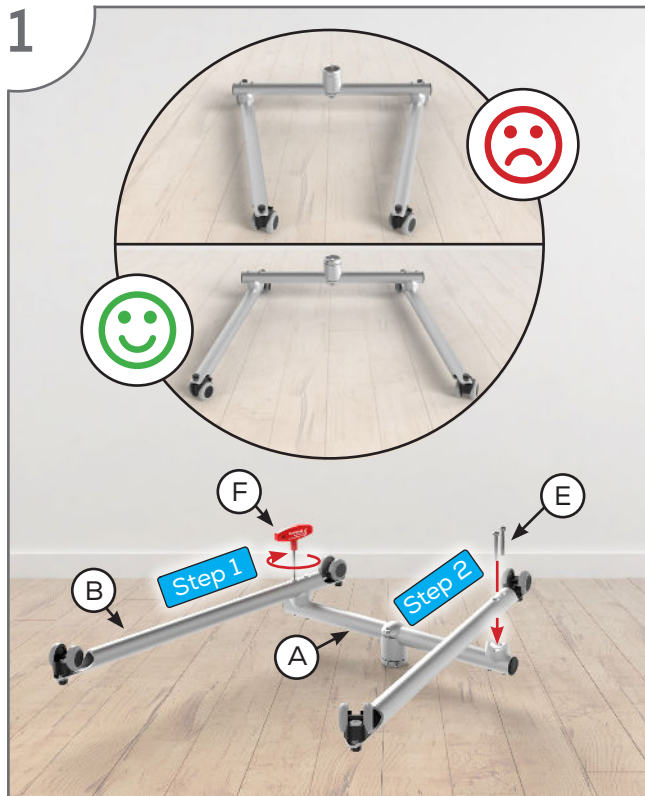

! Attention / Achtung



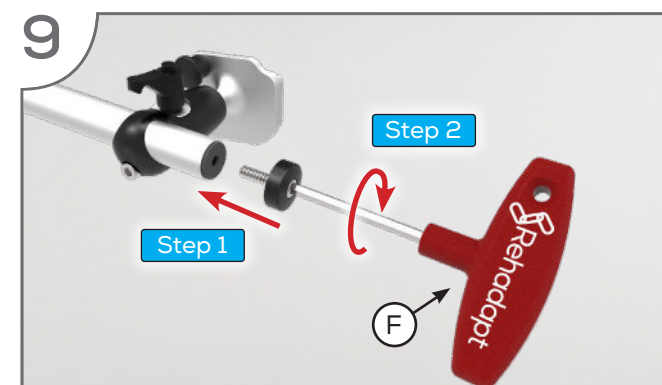
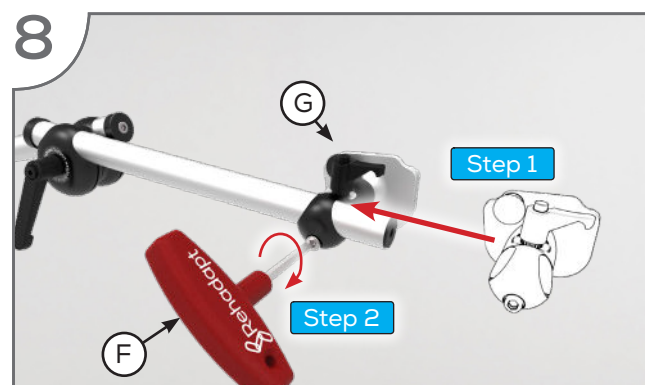
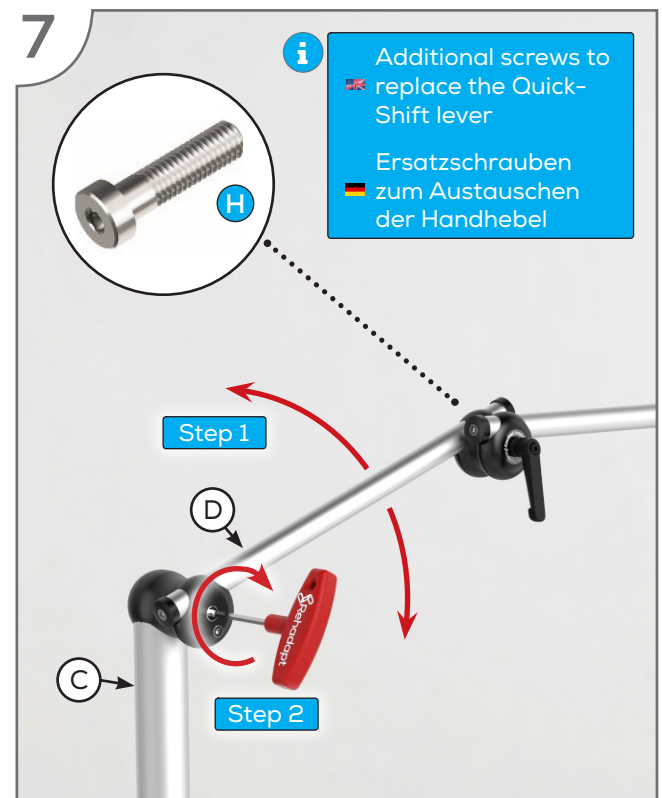
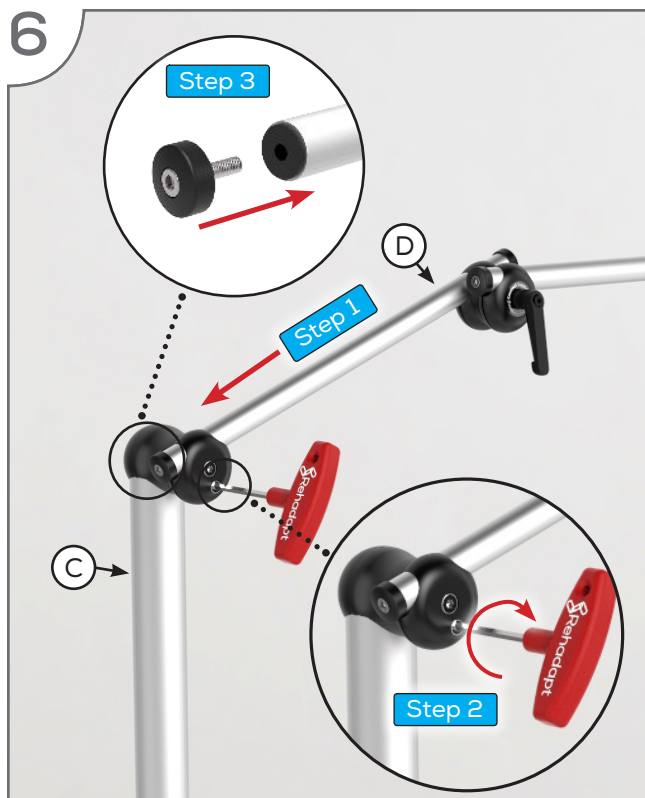
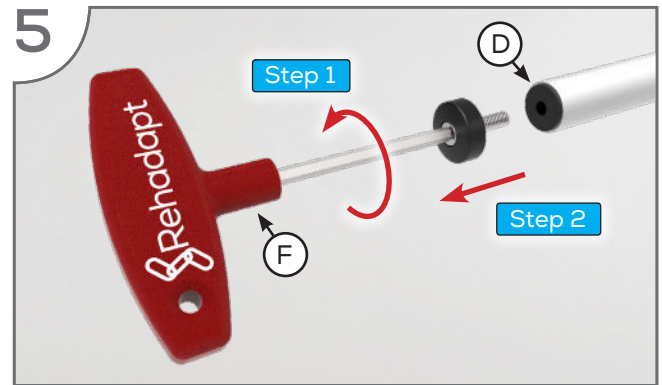
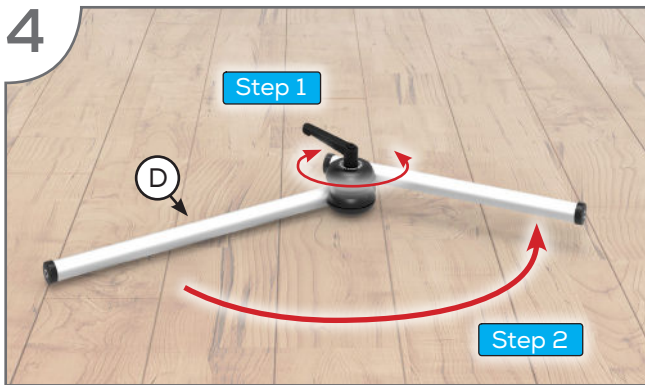



Attention / Achtung



Do not adjust/operate any hinge with a device mounted!

Remove the device before adjusting!

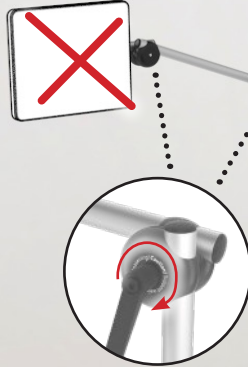

Betätigung/Verstellung jeglicher Gelenke nur mit abgenommenem Gerät!

Bitte Gerät vorher abnehmen!

